

JVC

SERVICE MANUAL

CD RECEIVER

KD-S675

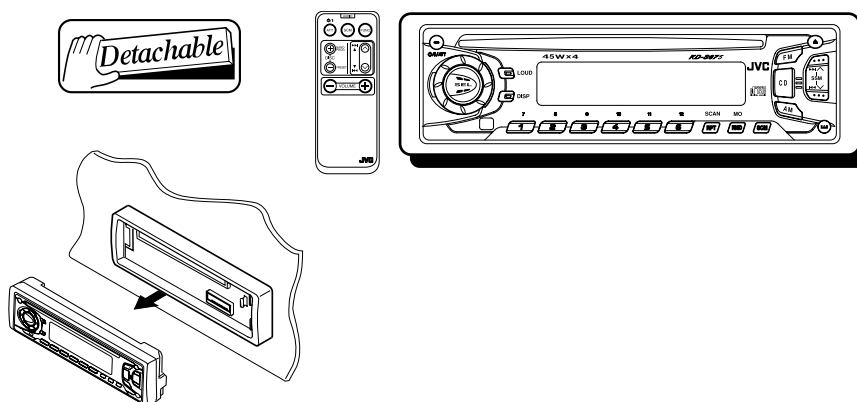

Area Suffix

U ----- Other Areas

COMPACT
disc
DIGITAL AUDIO

Contents

Safety precaution	1- 2
Preventing static electricity	1- 3
Disassembly method	1- 4
Adjustment method	1-11
Flow of functional until TOC read	1-12
Maintenance of laser pickup	1-14
Replacement of laser pickup	1-14
Description of major ICs	1-15~27

Safety precaution

 **CAUTION** Burrs formed during molding may be left over on some parts of the chassis. Therefore, pay attention to such burrs in the case of performing repair of this system.

 **CAUTION** Please use enough caution not to see the beam directly or touch it in case of an adjustment or operation check.

Preventing static electricity

1. Grounding to prevent damage by static electricity

Electrostatic discharge (ESD), which occurs when static electricity stored in the body, fabric, etc. is discharged, can destroy the laser diode in the traverse unit (optical pickup). Take care to prevent this when performing repairs.

2. About the earth processing for the destruction prevention by static electricity

Static electricity in the work area can destroy the optical pickup (laser diode) in devices such as CD players. Be careful to use proper grounding in the area where repairs are being performed.

2-1 Ground the workbench

Ground the workbench by laying conductive material (such as a conductive sheet) or an iron plate over it before placing the traverse unit (optical pickup) on it.

2-2 Ground yourself

Use an anti-static wrist strap to release any static electricity built up in your body.

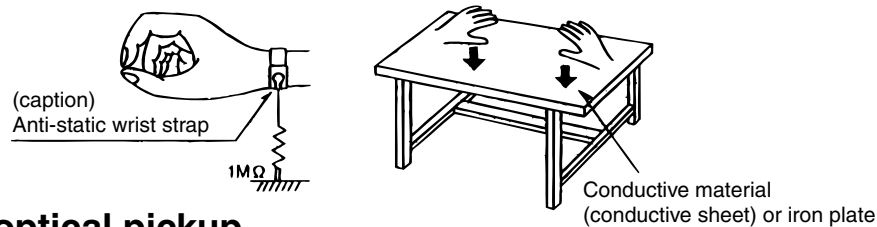

3. Handling the optical pickup

1. In order to maintain quality during transport and before installation, both sides of the laser diode on the replacement optical pickup are shorted. After replacement, return the shorted parts to their original condition. (Refer to the text.)
2. Do not use a tester to check the condition of the laser diode in the optical pickup. The tester's internal power source can easily destroy the laser diode.

4. Handling the traverse unit (optical pickup)

1. Do not subject the traverse unit (optical pickup) to strong shocks, as it is a sensitive, complex unit.
2. Cut off the shorted part of the flexible cable using nippers, etc. after replacing the optical pickup. For specific details, refer to the replacement procedure in the text. Remove the anti-static pin when replacing the traverse unit. Be careful not to take too long a time when attaching it to the connector.
3. Handle the flexible cable carefully as it may break when subjected to strong force.
4. It is not possible to adjust the semi-fixed resistor that adjusts the laser power. Do not turn it

Attention when traverse unit is decomposed

***Please refer to "Disassembly method" in the text for pick-up and how to detach the substrate.**

1. Solder is put up before the card wire is removed from connector on the CD substrate as shown in Figure.
(When the wire is removed without putting up solder, the CD pick-up assembly might destroy.)
2. Please remove solder after connecting the card wire with when you install picking up in the substrate.

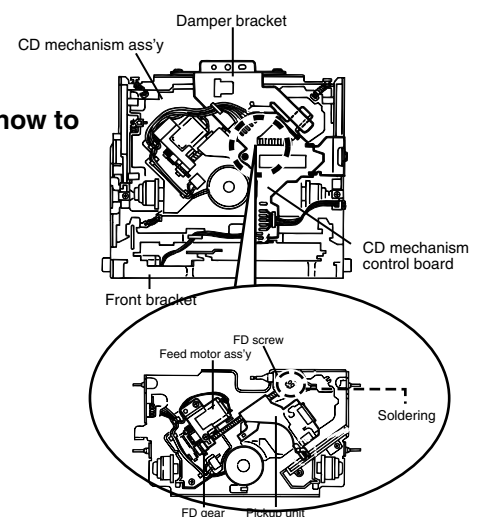

Disassembly method

<Main body>

■ Removing the front panel assembly (See Fig.1)

1. Press the eject button in the lower right part of the front panel. Remove the front panel assembly from the body.

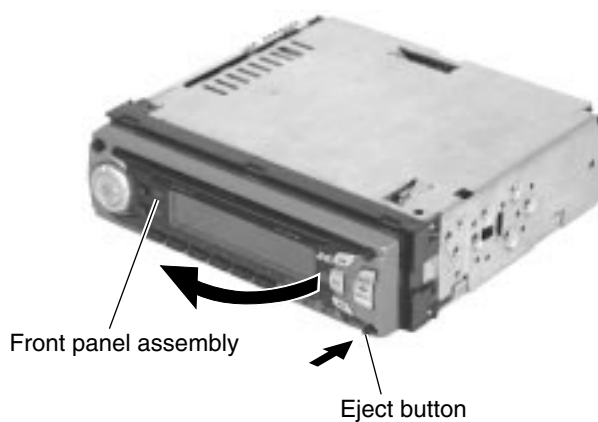

Fig.1

■ Removing the front chassis assembly (See Fig.2 and 3)

- Prior to performing the following procedure, remove the front panel assembly.
1. Release the four joint tabs **a** on both sides of the front chassis assembly and remove the front chassis assembly toward the front.

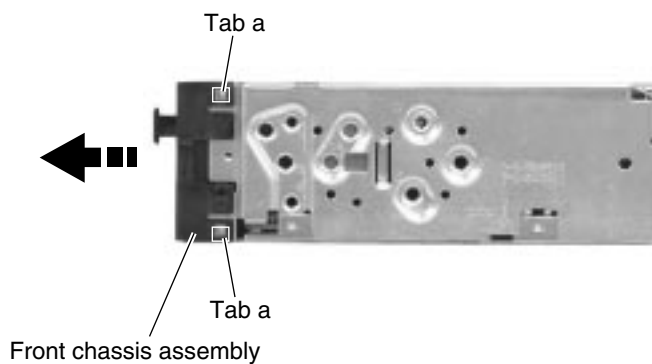

Fig.2

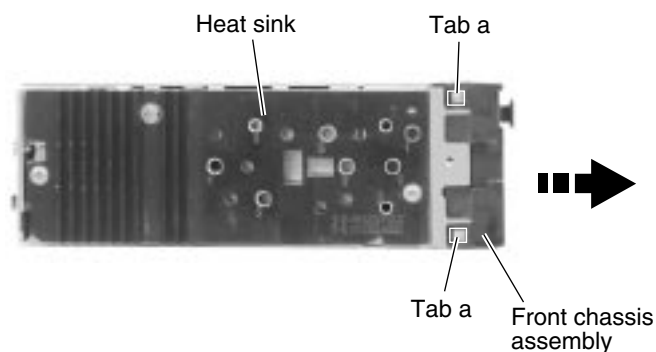

Fig.3

■ **Removing the heat sink (See Fig.4)**

1. Remove the three screws **A** on the left side of the body.

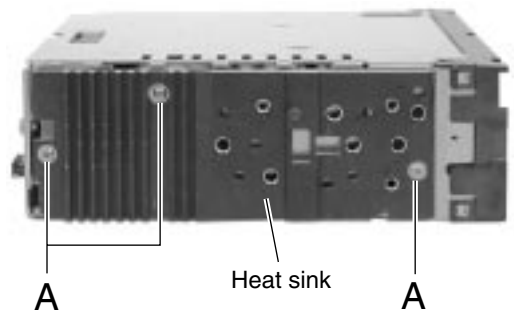

Fig.4

■ **Removing the bottom cover (See Fig.5 and 6)**

- Prior to performing the following procedure, remove the front panel assembly, the front chassis assembly and the heat sink.

1. Turn over the body and unjoint the five joints **b** with the bottom cover and the body using a screwdriver.

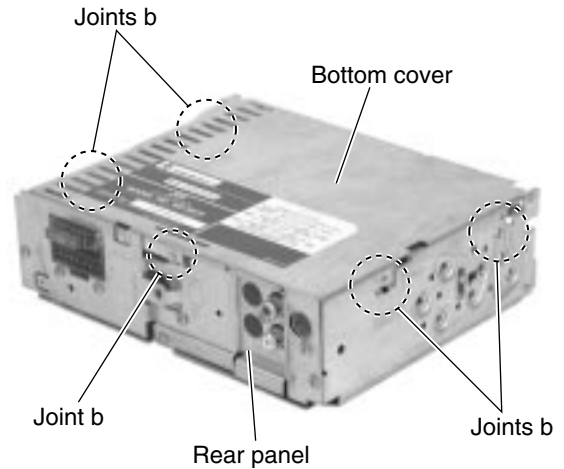

Fig.5

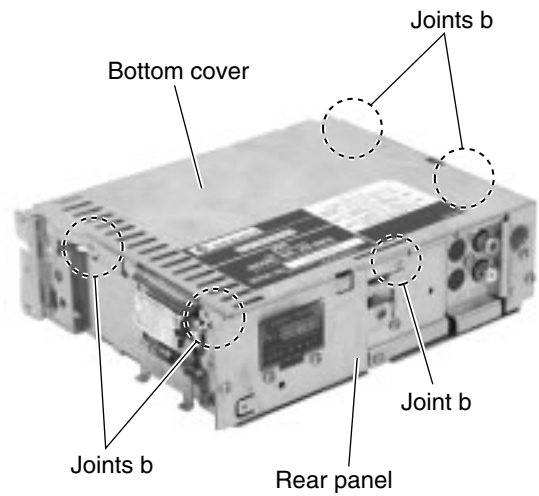

Fig.6

■ Removing the main board
(See Fig.7 and 8)

• Prior to performing the following procedure, remove the front panel assembly, the front chassis assembly, the heat sink and the bottom cover.

1. Remove the screw **B**, the four screws **C** and the three screws **D** attaching the rear panel on the back of the body. Remove the rear panel.
2. Remove the two screws **E** attaching the main board on the bottom of the body. Disconnect connector CN501 on the main board in the direction of the arrow.

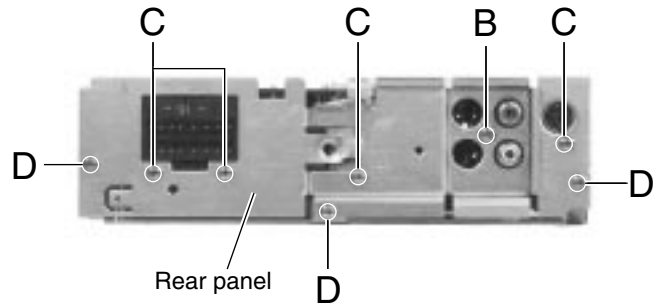

Fig.7

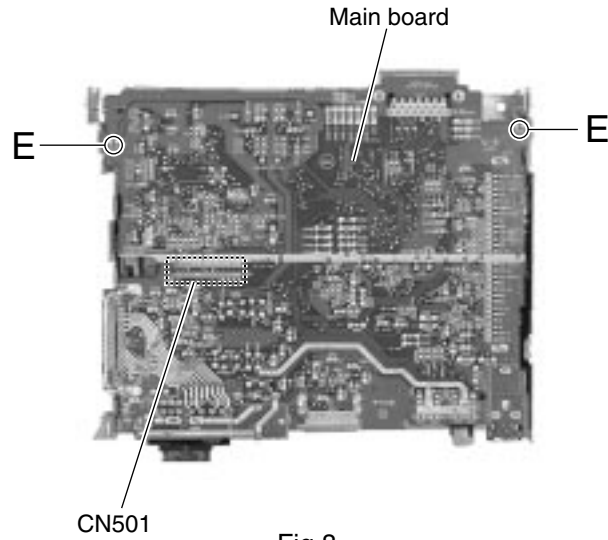

Fig.8

■ Removing the CD mechanism section
(See Fig.9)

• Prior to performing the following procedure, remove the front panel assembly, the front chassis assembly, the heat sink, the bottom cover and the main board.

1. Remove the three screws **F** attaching the CD mechanism section on the back of the top chassis.

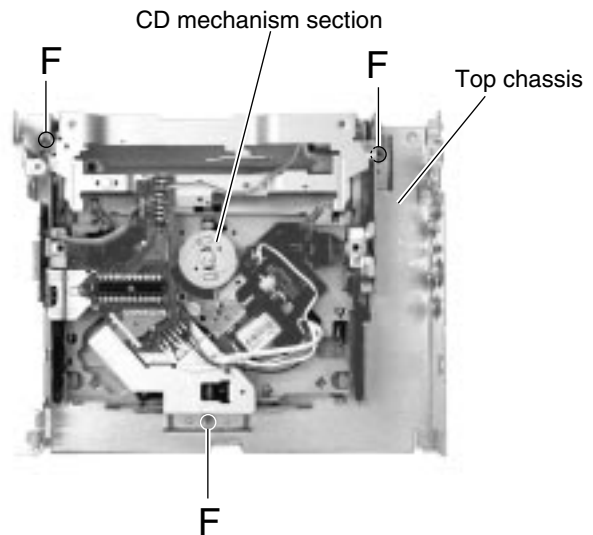

Fig.9

**■ Removing the control switch board
(See Fig.10 to 12)**

• Prior to performing the following procedure, remove the front panel assembly.

1. Remove the four screws **G** attaching the rear cover on the back of the front panel assembly.
2. Unjoint the eleven joints **c** with the front panel and the rear cover.
3. Remove the control switch board on the back of the front panel.

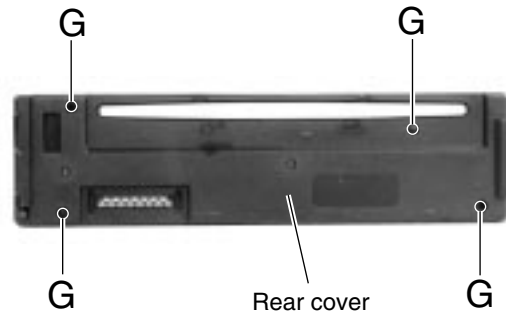

Fig.10

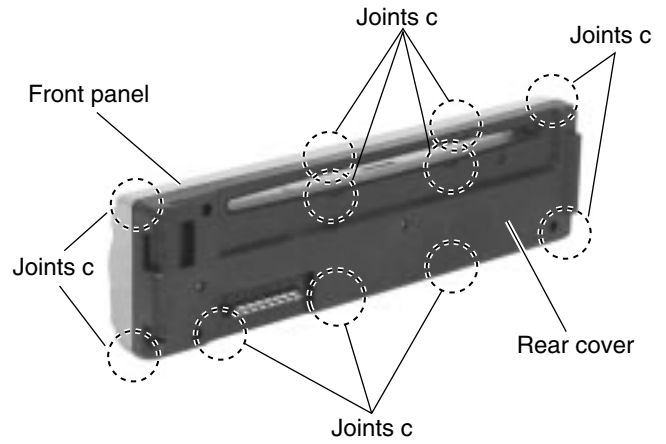

Fig.11

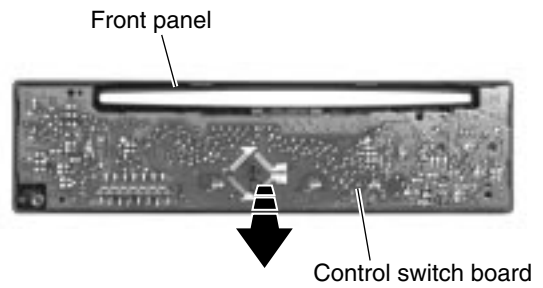

Fig.12

<CD mechanism section>

■ Removing the CD mechanism control board (See Fig.1 and 2)

1. Unsolder the part **a** and **b** on the CD mechanism control board.
2. Remove the stator fixing the CD mechanism control board and the damper bracket (To remove the stator smoothly, pick up the center part).
3. Remove the screw **A** attaching the CD mechanism control board.
4. Remove the CD mechanism control board in the direction of the arrow while releasing it from the two damper bracket slots **d** and the front bracket slot **e**.
5. Disconnect the flexible wire from connector on the pickup unit.

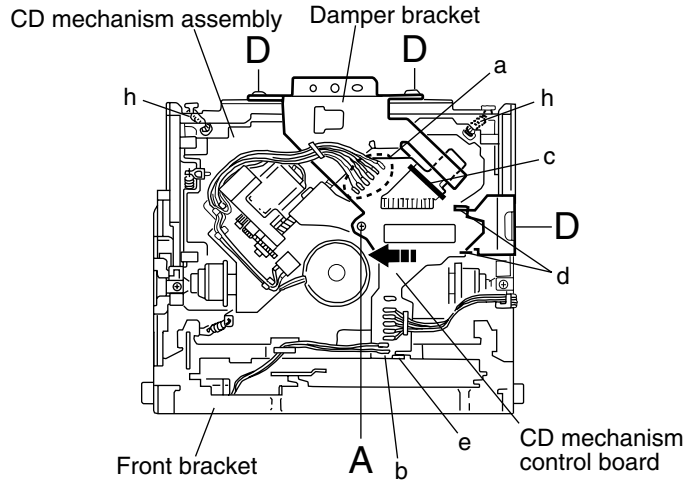

Fig.1

ATTENTION: Turn the FD gear in the direction of the arrow to move the entire pickup unit to the appropriate position where the flexible wire of the CD mechanism unit can be disconnected easily.
(Refer to Fig.2)

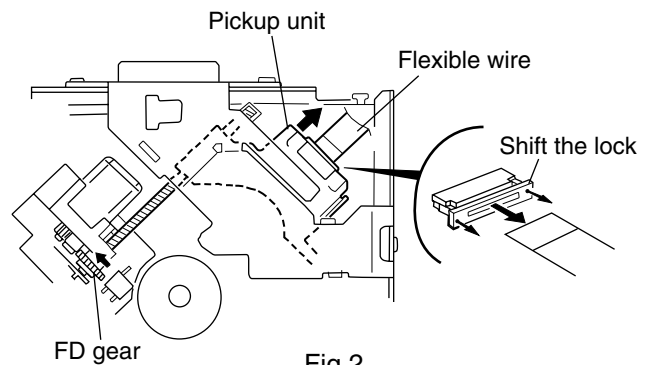

Fig.2

■ Removing the loading motor (See Fig.3 to 5)

- Prior to performing the following procedure, remove the CD mechanism control board.
1. Remove the two springs **f** attaching the CD mechanism assembly and the front bracket.
 2. Remove the two screws **B** and the front bracket while pulling the flame outward.
 3. Remove the belt and the screw **C** from the loading motor.

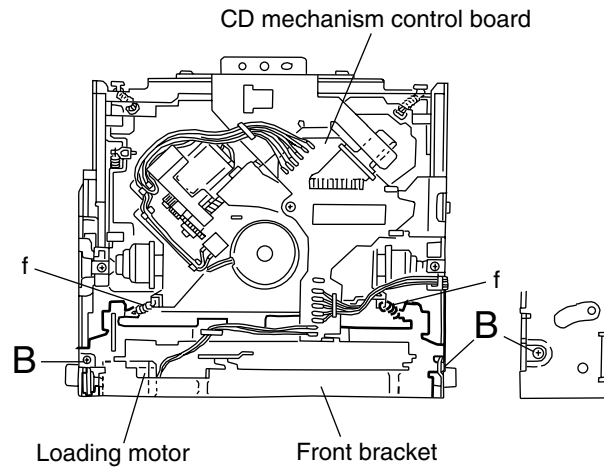

Fig.3

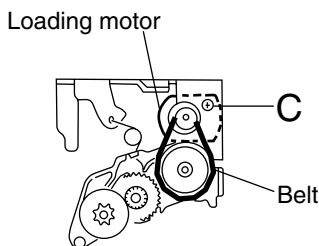

Fig.5

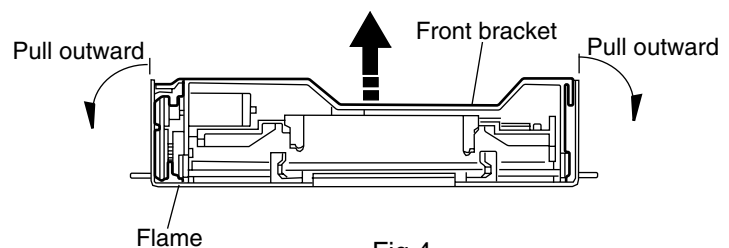

Fig.4

**■ Removing the CD mechanism assembly
(See Fig.1, 6 to 9)**

• Prior to performing the following procedure, remove the CD mechanism control board and the front bracket (loading motor).

1. Remove the three screws **D** and the damper bracket.
2. Raise the both sides fix arms and move the fix plates in the direction of the arrow to place the four shafts **g** as shown in Fig.8 and 9.
3. Remove the CD mechanism assembly and the two springs **h** attaching the flame.
4. Remove the two screws **E** and both sides rear damper brackets from the dampers. Detach the CD mechanism assembly from the left side to the right side.

ATTENTION: The CD mechanism assembly can be removed if only the rear damper bracket on the left side is removed.

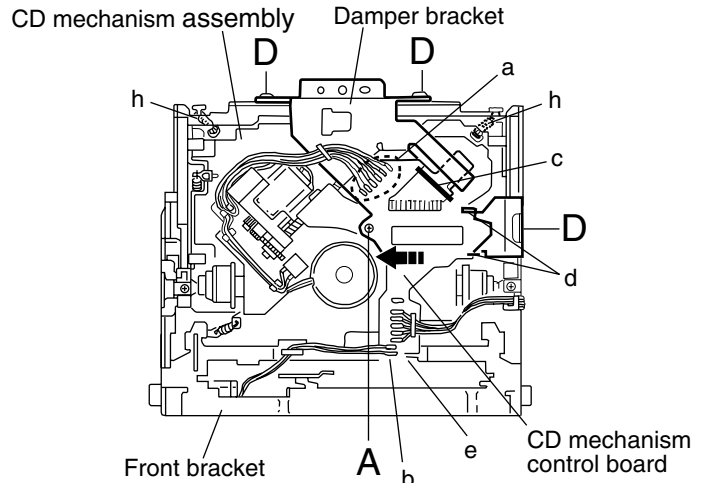

Fig.1

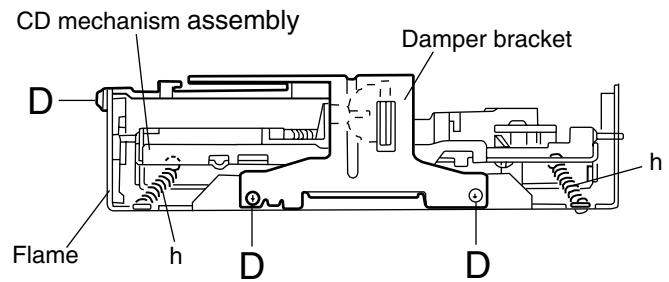

Fig.6

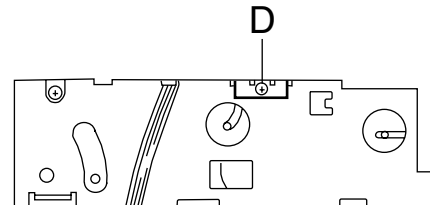

Fig.7

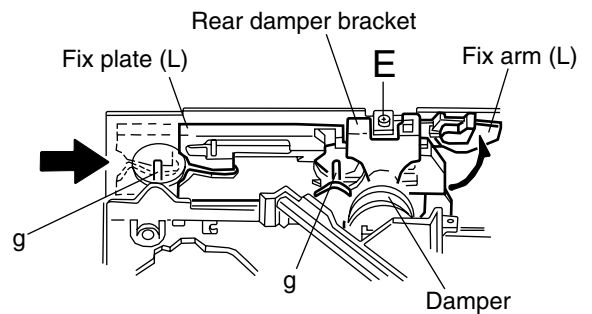

Fig.8

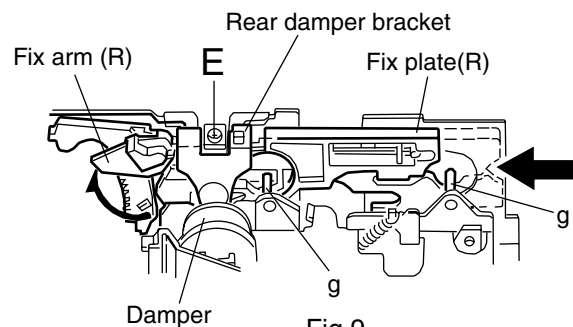

Fig.9

■ Removing the feed motor assembly
(See Fig.10)

- Prior to performing the following procedure, remove the CD mechanism control board, the front bracket (loading motor) and the CD mechanism assembly.

1. Remove the two screws **F** and the feed motor assembly.

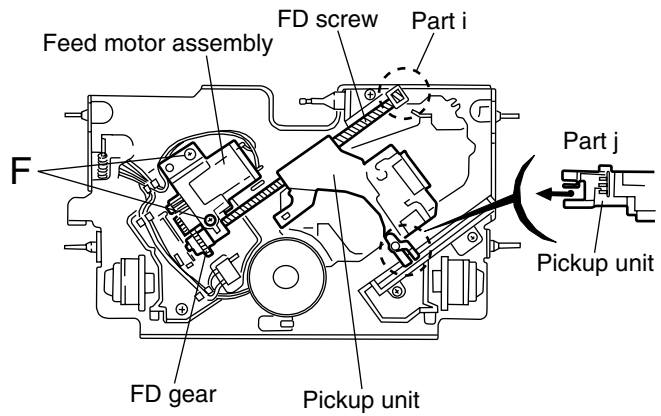

Fig.10

■ Removing the pickup unit
(See Fig.10 and 11)

- Prior to performing the following procedure, remove the CD mechanism control board, the front bracket (loading motor), the CD mechanism assembly and the feed motor assembly.

1. Detach the FD gear part of the pickup unit upward. Then remove the pickup unit while pulling out the part i of the FD screw.

ATTENTION: When reattaching the pickup unit, reattach the part j of the pickup unit, then the part i of the FD screw.

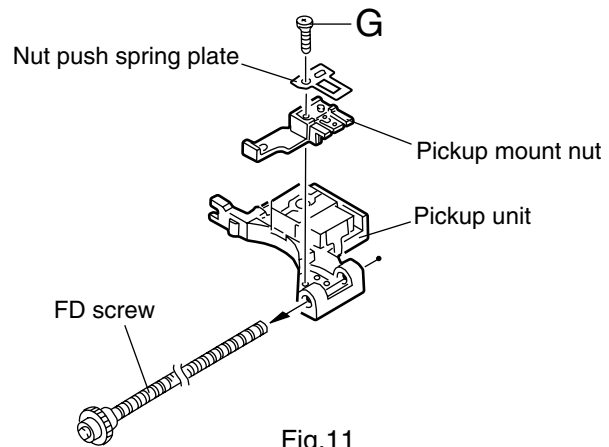

Fig.11

2. Remove the screw **G** attaching the nut push spring plate and the pickup mount nut from the pickup unit. Pull out the FD screw.

■ Removing the spindle motor
(See Fig.12 and 13)

- Prior to performing the following procedure, remove the CD mechanism control board, the front bracket (loading motor), the CD mechanism assembly and the feed motor assembly.

1. Turn up the CD mechanism assembly and remove the two springs **k** on both sides of the clamber arms. Open the clamber arm upward.

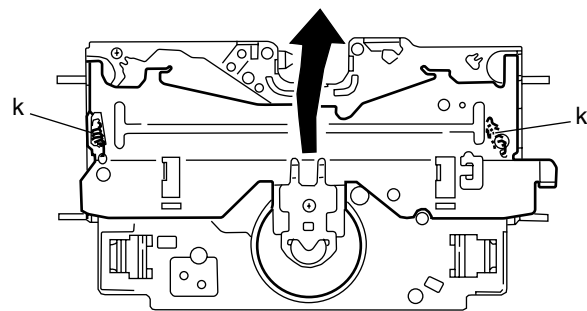

Fig.12

2. Turn the turn table, and remove the two screws **H** and the spindle motor.

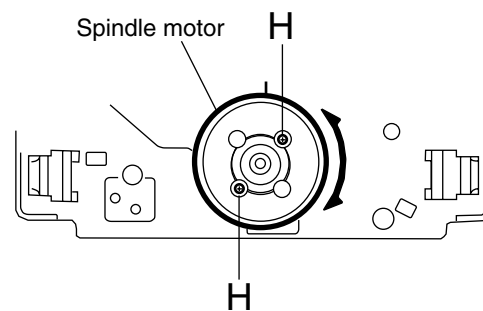

Fig.13

Adjustment method

■ Test instruments required for adjustment

1. Digital oscilloscope (100MHz)
2. AM Standard signal generator
3. FM Standard signal generator
4. Stereo modulator
5. Electric voltmeter
6. Digital tester
7. Tracking offset meter
8. Test Disc JVC :CTS-1000
9. Extension cable for check
EXTGS004-26P × 1

■ Standard volume position

Balance and Bass & Treble volume : Indication "0"
Loudness : OFF
BBE : OFF

■ Frequency Band

FM 87.5MHz ~ 108.0MHz
MW 531kHz ~ 1602 kHz

■ Dummy load

Exclusive dummy load should be used for AM, and FM. For FM dummy load, there is a loss of 6dB between SSG output and antenna input. The loss of 6dB need not be considered since direct reading of figures are applied in this working standard.

■ Standard measuring conditions

Power supply voltage DC14.4V(10.5~16V)
Load impedance 4 Ω (2 Speakers connection)
Line out impedance 20k Ω
Output Level Line out 2.0V (Vol. MAX)

■ How to connect the extension cable for adjusting

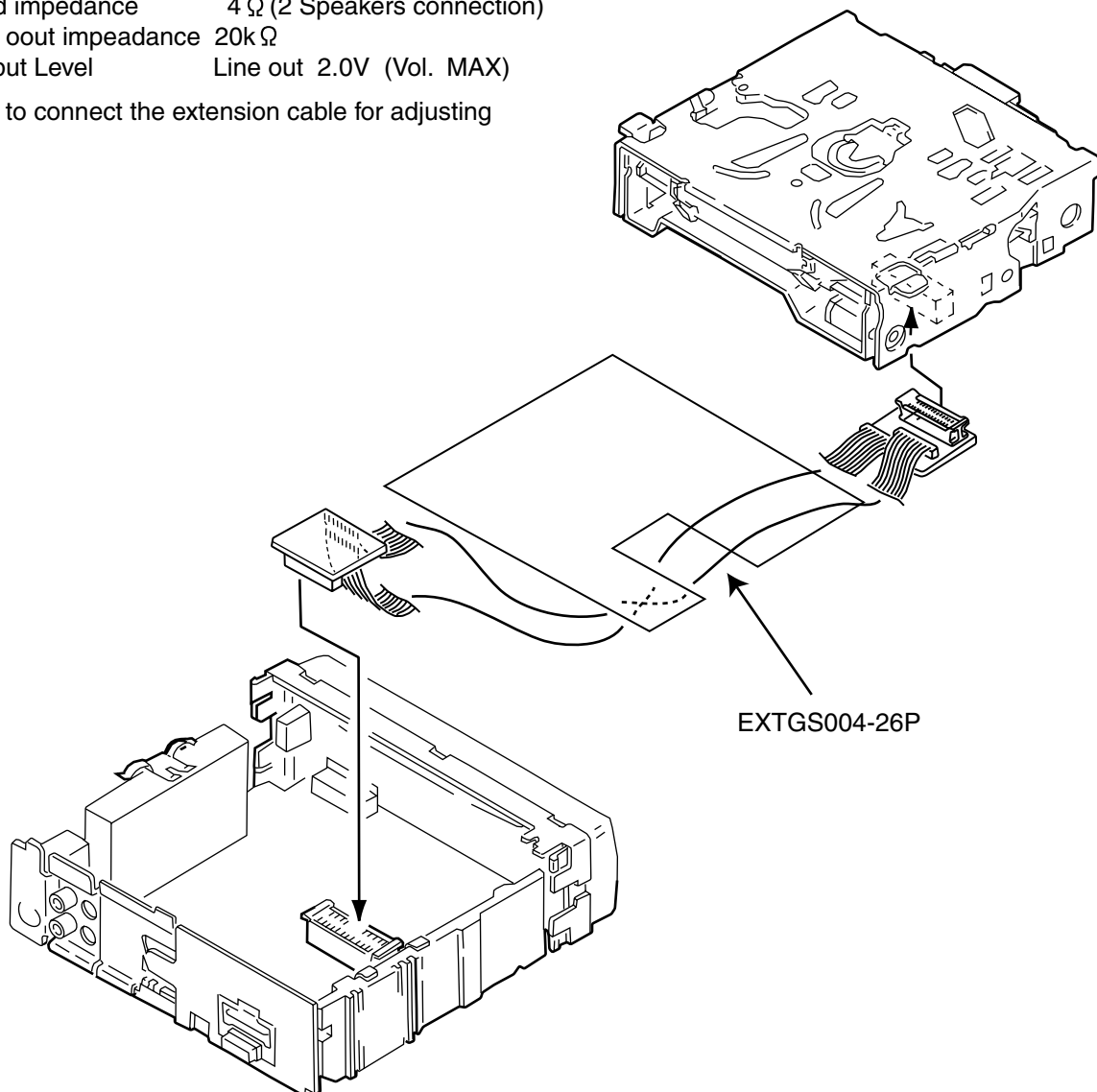

Flow of functional operation until TOC read

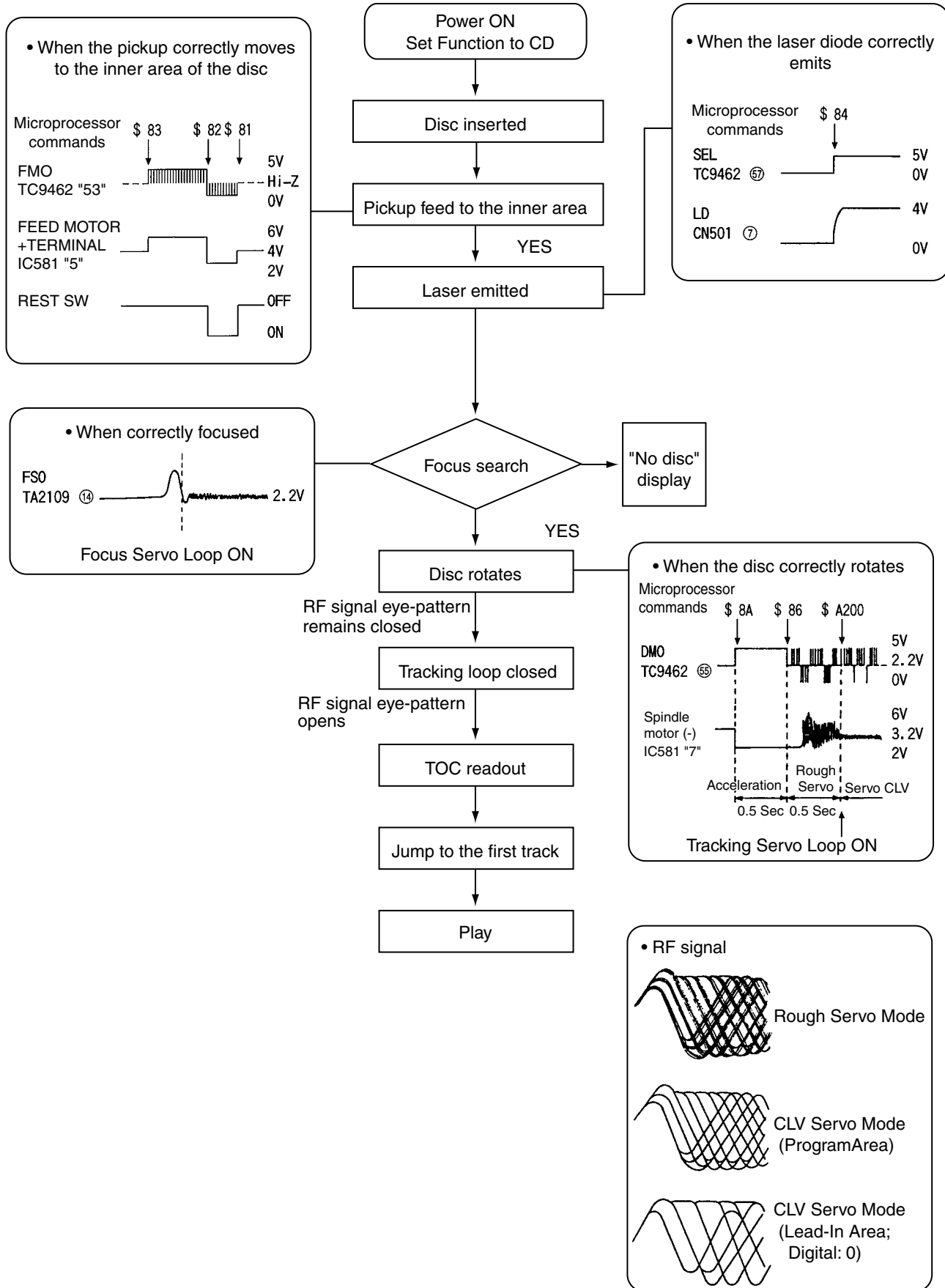

■ Feed Section

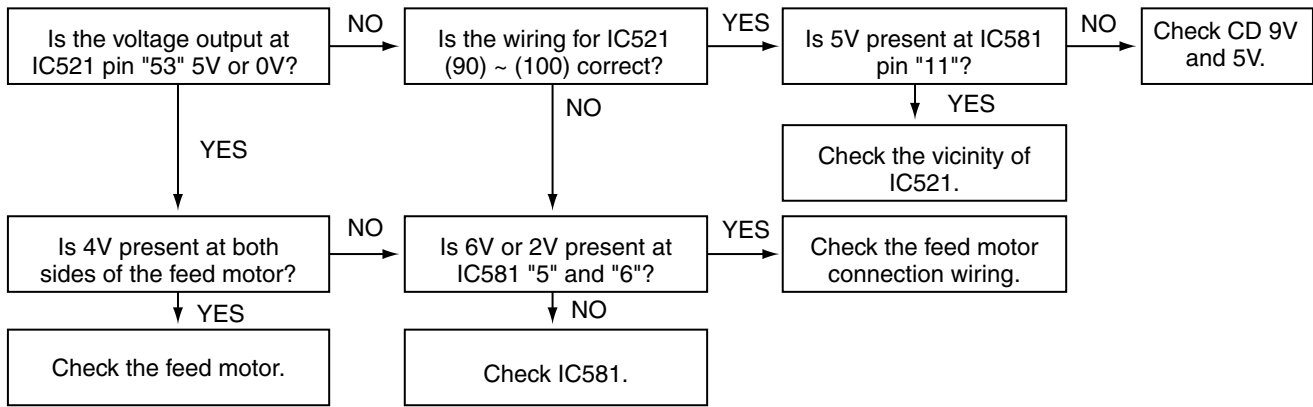

■ Focus Section

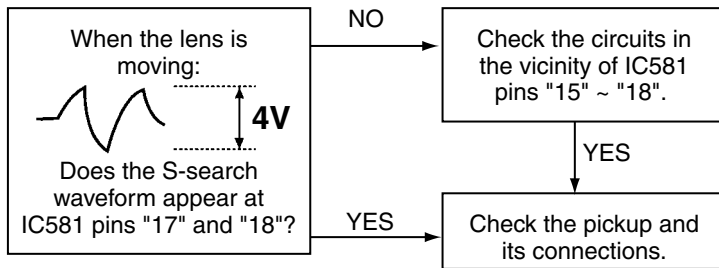

■ Spindle Section

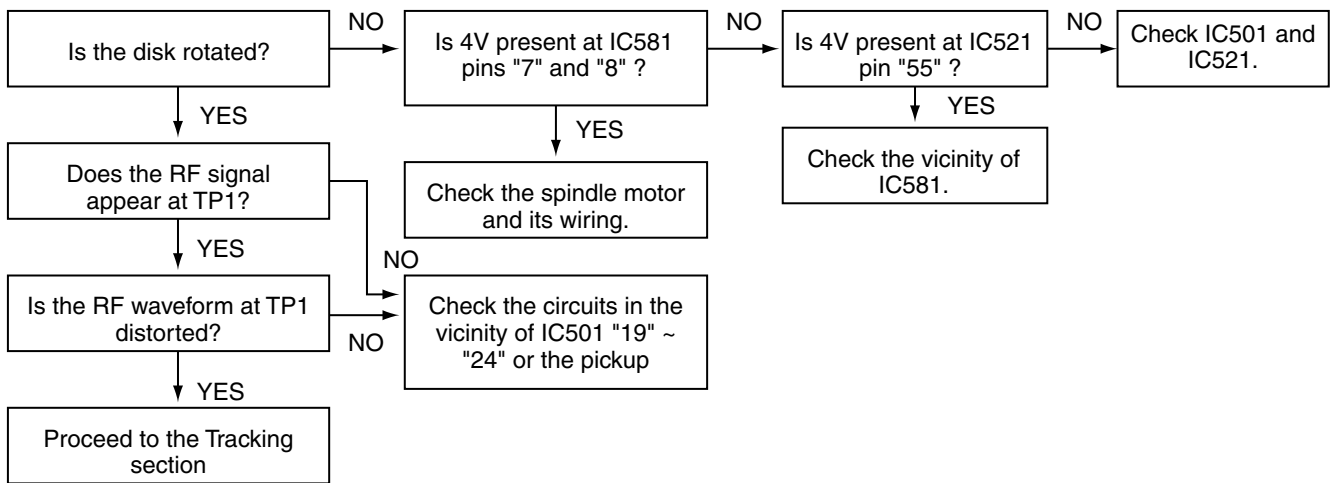

■ Tracking Section

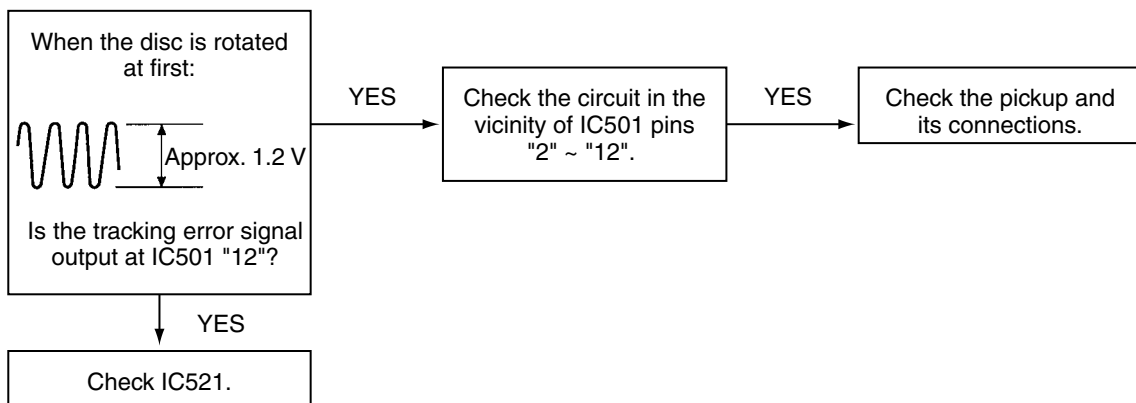

Maintenance of laser pickup

(1) Cleaning the pick up lens
 Before you replace the pick up, please try to clean the lens with a alcohol soaked cotton swab.

(2) Life of the laser diode
 When the life of the laser diode has expired, the following symptoms will appear.
 (1) The level of RF output (EFM output:amplitude of eye pattern) will be low.

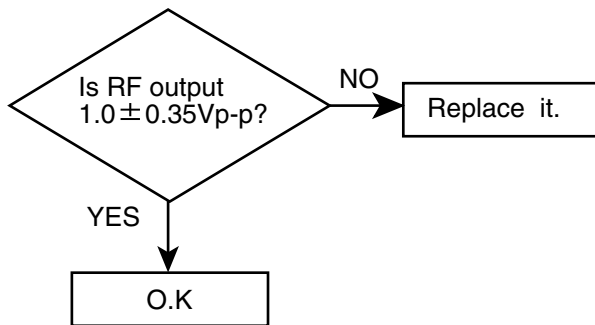

Replacement of laser pickup

(3) Semi-fixed resistor on the APC PC board
 The semi-fixed resistor on the APC printed circuit board which is attached to the pickup is used to adjust the laser power. Since this adjustment should be performed to match the characteristics of the whole optical block, do not touch the semi-fixed resistor.
 If the laser power is lower than the specified value, the laser diode is almost worn out, and the laser pickup should be replaced.
 If the semi-fixed resistor is adjusted while the pickup is functioning normally, the laser pickup may be damaged due to excessive current.

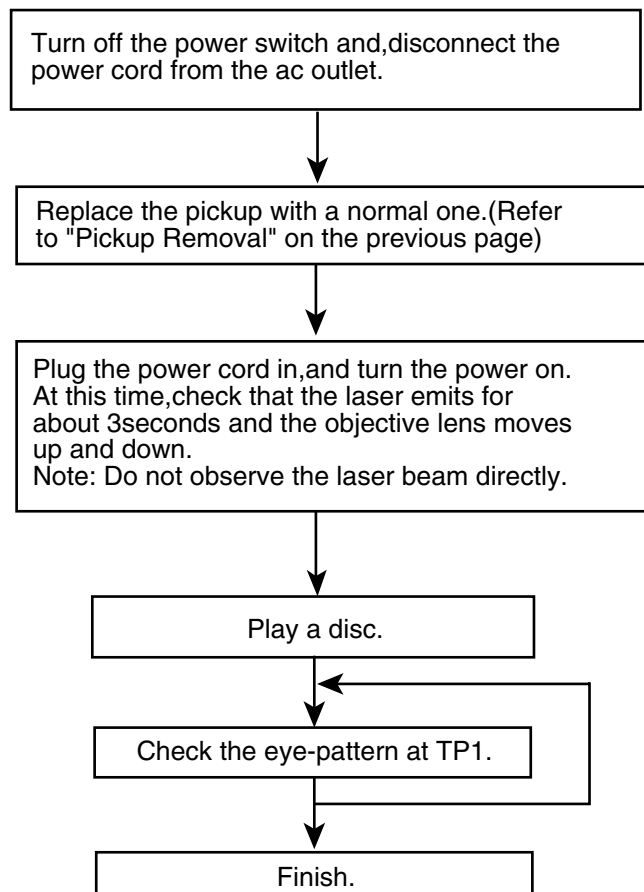

Description of major ICs

TEA6320T-X (IC931) : E.volume

1.Pin layout

2.Block diagram

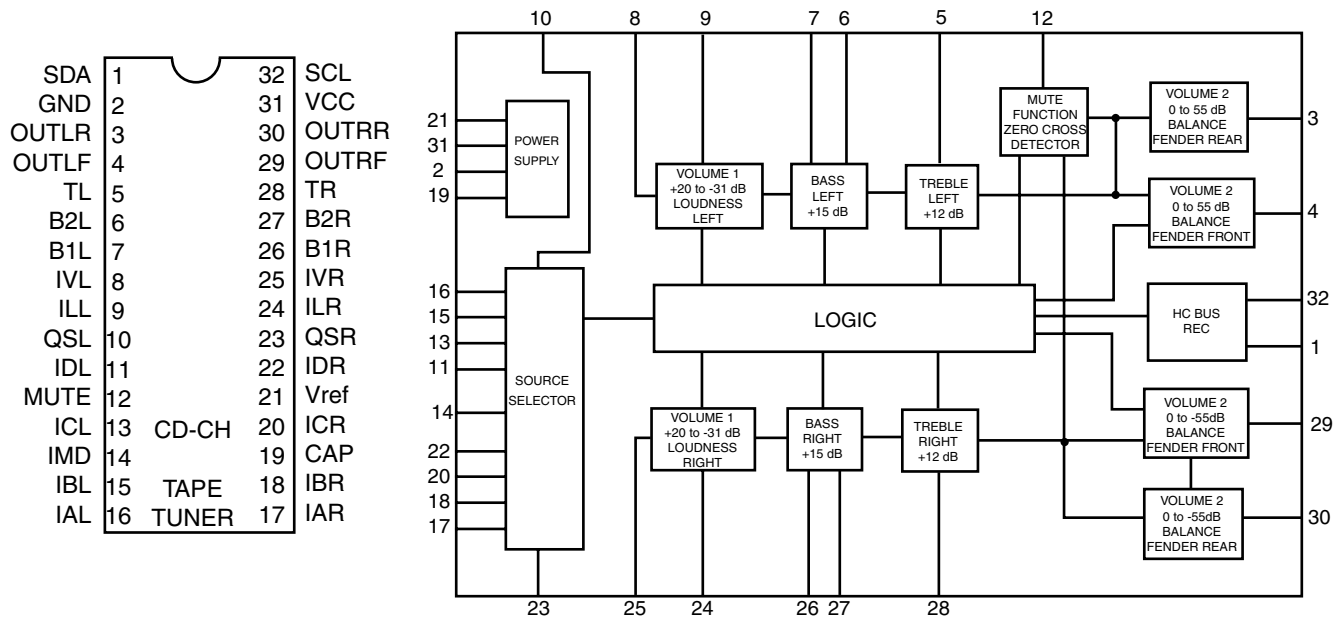

3.Pin functions

Pin No.	Symbol	I/O	Functions	Pin No.	Symbol	I/O	Functions
1	SDA	I/O	Serial data input/output.	17	IAR	I	Input A right source.
2	GND	-	Ground.	18	IBR	I	Input B right source.
3	OUTLR	O	output left rear.	19	CAP	-	Electronic filtering for supply.
4	OUTLF	O	output left front.	20	ICR	I	Input C right source.
5	TL	I	Treble control capacitor left channel or input from an external equalizer.	21	Vref	-	Reference voltage (0.5Vcc)
6	B2L	-	Bass control capacitor left channel or output to an external equalizer.	22	IDR	-	Not used
7	B1L	-	Bass control capacitor left channel.	23	QSR	O	Output source selector right channel.
8	IVL	I	Input volume 1. left control part.	24	ILR	I	Input loudness right channel.
9	ILL	I	Input loudness. left control part.	25	IVR	I	Input volume 1. right control part.
10	QSL	O	Output source selector. left channel.	26	B1R	-	Bass control capacitor right channel
11	IDL	-	Not used	27	B2R	O	Bass control capacitor right channel or output to an external equalizer.
12	MUTE	-	Not used	28	TR	I	Treble control capacitor right channel or input from an external equalizer.
13	ICL	I	Input C left source.	29	OUTRF	O	Output right front.
14	IMO	-	Not used	30	OUTRR	O	Output right rear.
15	IBL	I	Input B left source.	31	Vcc	-	Supply voltage.
16	IAL	I	Input A left source.	32	SCL	I	Serial clock input.

■ AN8806SB-W (IC501) : RF & Servo amp.

1.Pin layout

PD 1	36 PDAC
LD 2	35 PDBD
LDON 3	34 PDF
LDP 4	33 PDE
VCC 5	32 PDER
RF- 6	31 PDFR
RF OUT 7	30 TBAL
RF IN 8	29 FBAL
C.AGC 9	28 EF-
ARF 10	27 EF OUT
C.ENV 11	26 TE-
C.EA 12	25 TE OUT
CS BDO 13	24 CROSS
BDO 14	23 TE BPF
CS BRT 15	22 VDET
OFTR 16	21 LD OFF
/NRFDET 17	20 VREF
GND 18	19 ENV

2.Block diagram

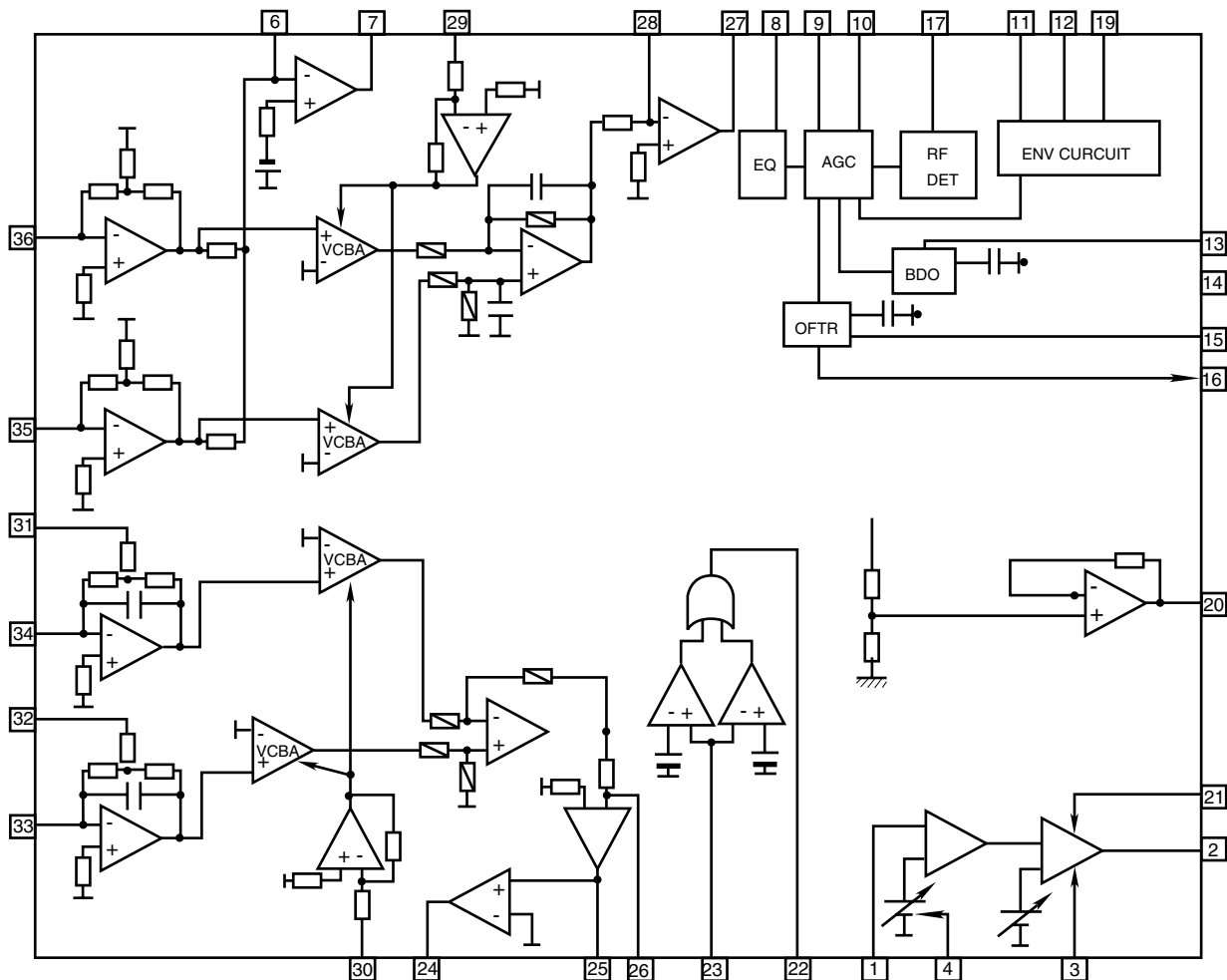

3. Pin function

Pin No.	Symbol	I/O	Function
1	PD	I	APC amp . Input terminal
2	LD	O	APC amp . Output terminal
3	LD ON	I	LD ON/OFF control terminal
4	LDP	--	Connect to GND
5	VCC	--	Power supply
6	RF-	I	RF amp . Reversing input terminal
7	RF OUT	O	RFamp . Output terminal
8	RF IN	I	AGC input terminal
9	C.AGC	I/O	AGC loop filter connection terminal
10	ARF	O	ARF output terminal
11	C.ENV	I/O	RF detection capacity connection terminal
12	C.EA	I/O	HPF-amp capacity connection terminal
13	CS BDO	I/O	Capacity connection terminal for RF discernment side envelope detection
14	BDO	O	BDO output terminal
15	CS BRT	I/O	Capacity connection terminal for RF discernment side envelope detection
16	OFTR	O	OFTR output terminal
17	/NRFDET	O	RFDET output terminal
18	GND	--	Connect to GND
19	ENV	O	3TENV output terminal
20	VREF	O	VREF output terminal
21	LD OFF	--	APC OFF control terminal
22	VDET	O	VDET output terminal
23	TE BPF	I	VDET input terminal
24	CROSS	O	CROSS output terminal
25	TE OUT	O	TE amp . Output terminal
26	TE-	I	FE amp . Reversing input terminal
27	FE OUT	O	FE amp . output terminal
28	FE-	I	FE amp . Reversing input terminal
29	FBAL	I	F.BAL control terminal
30	TBAL	I	T.BAL control terminal
31	PDFR	I/O	I-V amp conversion resistance adjustment terminal
32	PDER	I/O	I-V amp conversion resistance adjustment terminal
33	PDF	I	I-V amp input terminal
34	PDE	I	I-V amp input terminal
35	PD BD	I	I-V amp input terminal
36	PD AC	I	I-V amp input terminal

■ LA4743B(IC321) : Power amp.

1. Block diagram

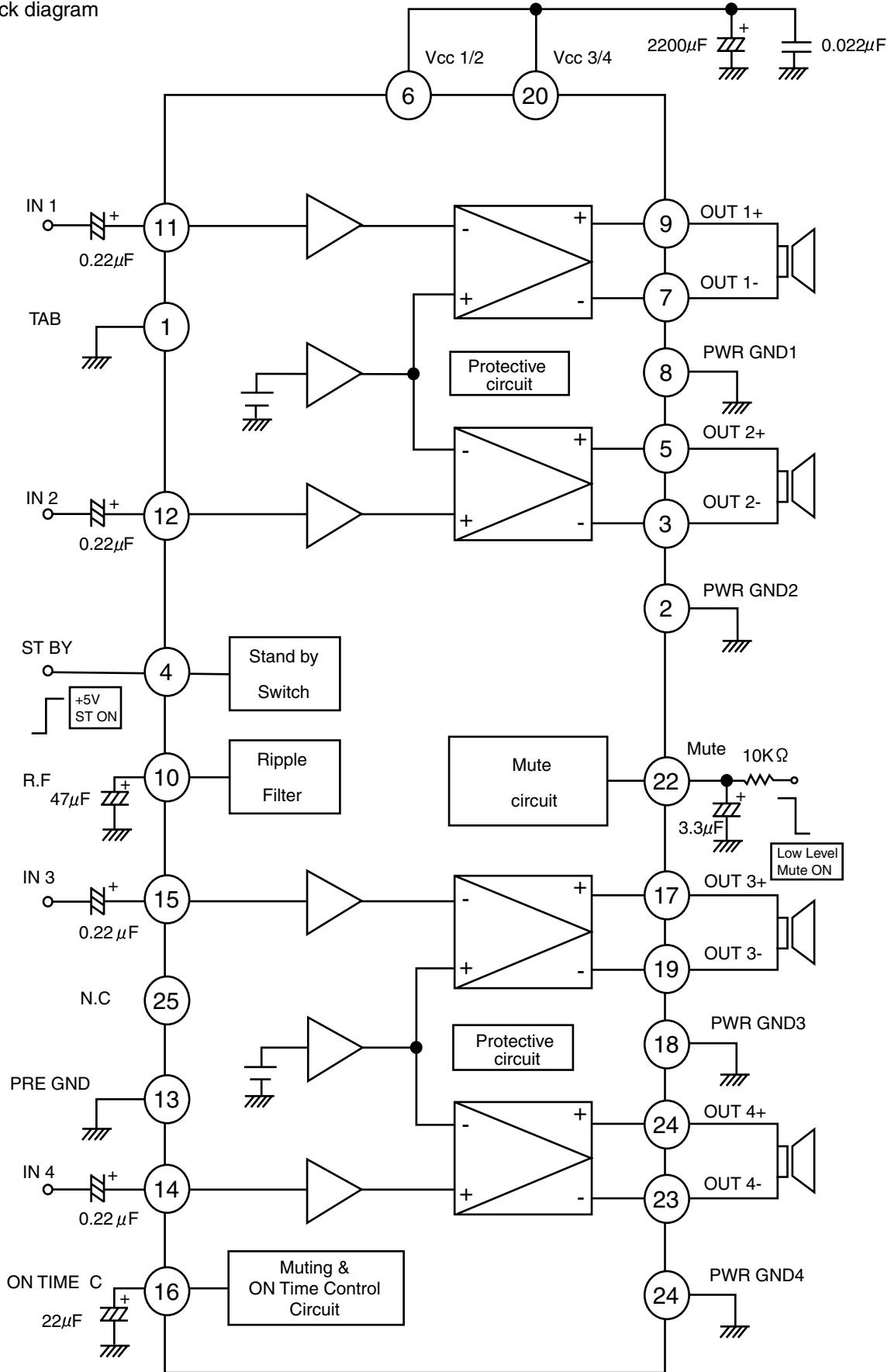

2. Terminal layout

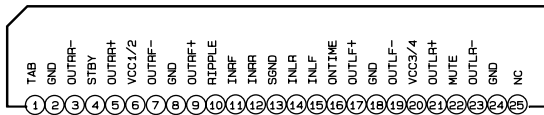

3. Pin function

Pin No.	Symbol	Function
1	TAB	Header of IC
2	GND	Power GND
3	OUTRR-	Output(-) for front Rch
4	STBY	Stand by input
5	OUTRR+	Output (+) for front Rch
6	VCC1/2	Power input
7	OUTRF-	Output (-) for rear Rch
8	GND	Power GND
9	OUTRF+	Output (+) for rear Rch
10	RIPPLE	Ripple filter
11	INRF	Rear Rch input
12	INRR	Front Rch input
13	SGND	Signal GND
14	INLR	Front Lch input
15	INLF	Rear Lch input
16	ONTIME	Power on time control
17	OUTLF+	Output (+) for rear Lch
18	GND	Power GND
19	OUTLF-	Output (-) for rear Lch
20	VCC3/4	Power input
21	OUTLR+	Output (+) for front
22	MUTE	Muting control input
23	OUTLR-	Output (-) for front
24	GND	Power GND
25	NC	Non connection

■ NJM4565M-WE (IC351) : Ope. amp

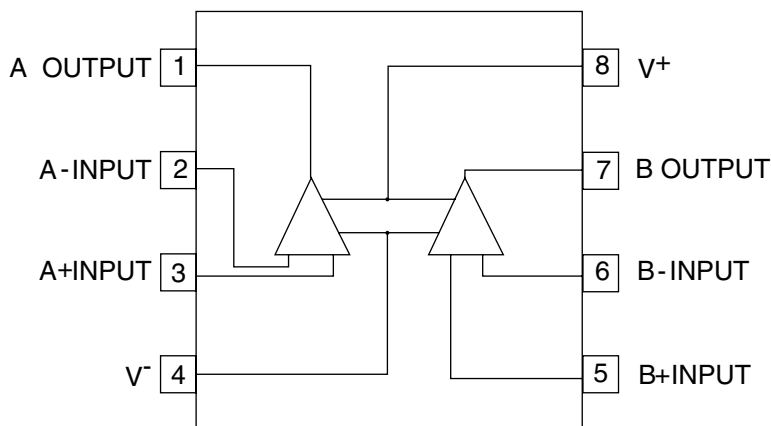

■ LA6567H-X(IC541) : CD driver

1.Pin layout & blockdiagram

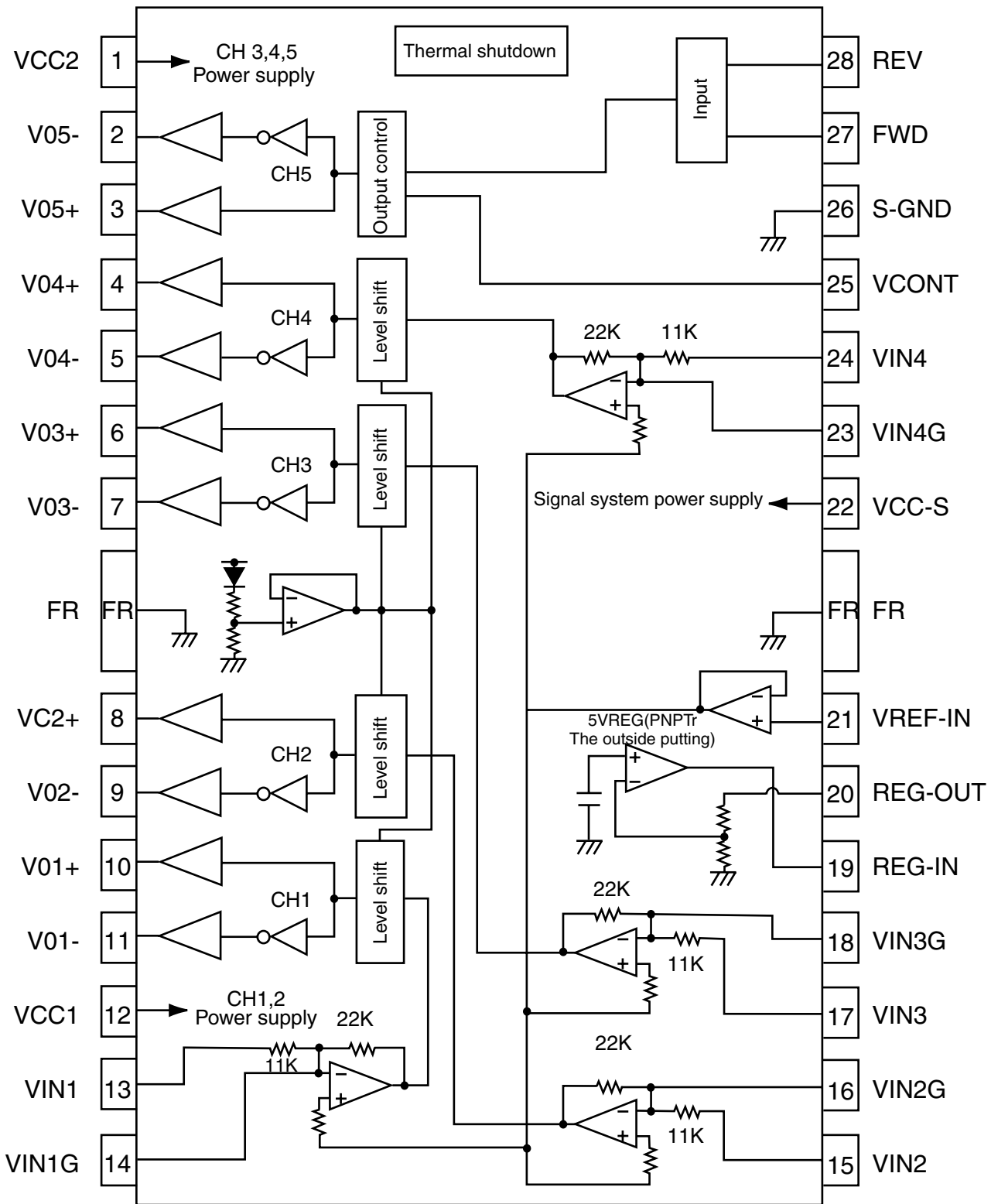

2. Pin function

LA6567H-X(2/2)

Pin no.	Symbol	Function
1	VCC2	CH3,4,5 Power supply(It is short with VCC1,VCC-S)
2	V05-	Loading output(-)
3	V05+	Loading terminal (+)
4	V04+	CH4 Output terminal(+)
5	V04-	CH4 Output terminal(-)
6	V03+	CH3 Output terminal(+)
7	V03-	CH3 Output terminal(-)
8	V02+	CH2 Output terminal(+)
9	V02-	CH2 Output terminal(-)
10	V01+	CH1 Output terminal(+)
11	V01-	CH1 Output terminal(-)
12	VCC1	CH1,2(BTL) Power supply(It is short with VCC-S,VCC2)
13	VIN1	CH1 Input terminal
14	VIN1G	CH1 Input terminal(For gain adjustment)
15	VIN2	CH2 Input terminal
16	VIN2G	CH2 Input terminal(For gain adjustment)
17	VIN3	CH3 Input terminal
18	VIN3G	CH3 Input terminal(For gain adjustment)
19	REG-IN	Regulator terminal(Outside putting PNP base)
20	REG-OUT	Regulator terminal(Outside putting PNP collector)
21	VREF-IN	Standard voltage input terminal
22	VCC-S	Signal system power supply(It is short with VCC1,VCC2)
23	VIN4G	CH4 Input terminal(For gain adjustment)
24	VIN4	CH4 Input terminal
25	VCONT	5CH(VLO) Output voltage set terminal
26	S-GND	Signal system GND
27	FWD	5CH(VLO)Signal output switch terminal(FWD),Input of logic of loading part 5CH(VLO)Signal output switch terminal(REV),
28	REV	Input of logic of loading part

* Frame(FR)at the center becomes system GND power.

* Please be short-circuited on the outside and use the terminal of the power supply system and three terminals of VCC-S, VCC1,VCC2.

MN35510 (IC561) : Digital servo & digital signal processor

1. Terminal Layout

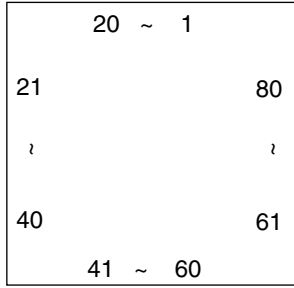

2. Block Diagram

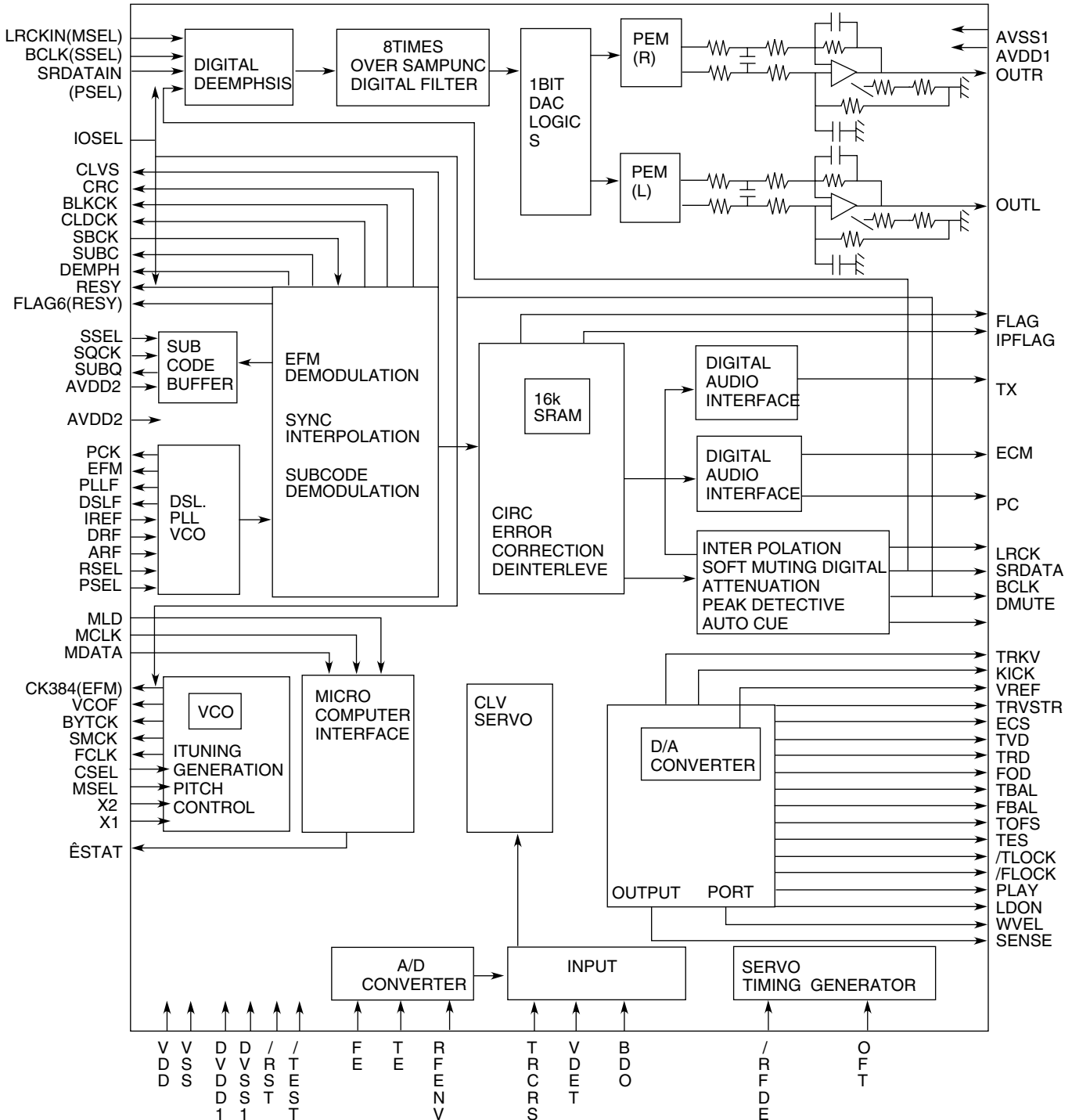

3. Description

Pin No.	symbol	I/O	Function	Pin No.	symbol	I/O	Function
1	BCLK	O	Not used	41	TES	O	Tracking error shunt signal output(H:shunt)
2	LRCK	O	Not used	42	PLAY	—	Not used
3	SRDATA	O	Not used	43	WVEL	—	Not used
4	DVDD1	—	Power supply (Digital)	44	ARF	I	RF signal input
5	DVSS1	—	Connected to GND	45	IREF	I	Reference current input pin
6	TX	O	Digital audio interface output	46	DRF	I	Bias pin for DSL
7	MCLK	I	Micom command clock signal input (Data is latched at signal's rising point)	47	DSL F	I/O	Loop filter pin for DSL
8	MDATA	I	Micom command data input	48	PLL F	I/O	Loop filter pin for PLL
9	MLD	I	Micom command load signal input	49	VCOF	—	Not used
10	SENSE	O	Sense signal output	50	AVDD2	—	Power supply(Analog)
11	FLOCK	O	Focus lock signal output Active :Low	51	AVSS2	—	Connected to GND(Analog)
12	TLOCK	O	Tracking lock signal output Active :Low	52	EFM	—	Not used
13	BLKCK	O	sub-code - block - clock signal output	53	PCK	—	Not used
14	SQCK	I	Outside clock for sub-code Q resister input	54	PDO	—	Not used
15	SUBQ	O	Sub-code Q -code output	55	SUBC	—	Not used
16	DMUTE	—	Connected to GND	56	SBCK	—	Not used
17	STATUS	O	Status signal (CRC,CUE,CLVS,TTSTOP,ECLV,SQOK)	57	VSS	—	Connected to GND(for X'tal oscillation circuit)
18	RST	I	Reset signal input (L:Reset)	58	XI	I	Input of 16.9344MHz X'tal oscillation circuit
19	SMCK	—	Not used	59	X2	O	Output of X'tal oscillation circuit
20	PMCK	—	Not used	60	VDD	—	Power supply(for X'tal oscillation circuit)
21	TRV	O	Traverse enforced output	61	BYTCK	—	Not used
22	TVD	O	Traverse drive output	62	CLDCK	—	Not used
23	PC	—	Not used	63	FLAG	—	Not used
24	ECM	O	Spindle motor drive signal (Enforced mode output) 3-State	64	IPPLAG	—	Not used
25	ECS	O	Spindle motor drive signal (Servo error signal output)	65	FLAG	—	Not used
26	KICK	O	Kick pulse output	66	CLVS	—	Not used
27	TRD	O	Tracking drive output	67	CRC	—	Not used
28	FOD	O	Focus drive output	68	DEMPH	—	Not used
29	VREF	I	Reference voltage input pin for D/A output block (TVD,FOD,FBA,TBAL)	69	RESY	—	Not used
30	FBAL	O	Focus Balance adjust signal output	70	IOSEL	—	pull up
31	TBAL	O	Tracking Balance adjust signal output	71	TEST	—	pull up
32	FE	I	Focus error signal input(Analog input)	72	AVDD1	—	Power supply(Digital)
33	TE	I	Tracking error signal input(Analog input)	73	OUT L	O	Lch audio output
34	RF ENV	I	RF envelope signal input(Analog input)	74	AVSS1	—	Connected to GND
35	VDET	I	Vibration detect signal input(H:detect)	75	OUT R	O	Rch audio output
36	OFT	I	Off track signal input(H:off track)	76	RSEL	—	pull up
37	TRCRS	I	Track cross signal input	77	CSEL	—	Connected to GND
38	RFDET	I	RF detect signal input(L:detect)	78	PSEL	—	Connected to GND
39	BDO	I	BDO input pin(L:detect)	79	MSEL	—	Connected to GND
40	LDON	O	Laser ON signal output(H:on)	80	SSEL	—	Pull up

■ LC72366-9989 (IC601) : Main micon

1. Pin layout

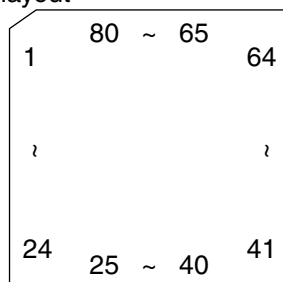

2. Pin function

Pin No.	Symbol	Function	Pin No.	Symbol	Function
1	XIN	4.5MHz crystal oscillation	41	CD ON	CD 8V supply on
2	TEST2	Connect to ground	42	RELAY	5V power control
3	J BUS SI	J-BUS signal data input (to 74HC126)	43	BBE CTL	No use
4	J BUS SO	J-BUS signal data output (to 74HC126)	44	BEEP	No use
5	J BUS SCK	J-BUS output clock signal (to 74HC126)	45	SW4	
6	J BUS I/O CONT	J-BUS I/O control	46	SW1	CD mechanism switch 1 for disc in, 8cm disc
7	SUBQ	CD LSI sub code data input	47	SW3	CD mecha. switch 3 for disc present, loading end
8		No use	48	REST	CD pickup rest position
9	SQCK	CD LSI sub code clock	49	JOG0	Rotary encoder input 0
10	RESET	Micon reset pin	50	JOG1	Rotary encoder input 1
11	LCD SI	No use	51	CD SENSE	CD LSI sense signal
12	LCD SO	LCD driver data output	52	STATUS	CD LSI status signal
13	LCD SCK	LCD driver clock signal	53	PSAVE2	Power save 2 : +B detect
14	LCD CE	LCD driver chip enable port	54	SD/ST	Station detection, Stereo indication
15	FM ILLUMI	No use	55	REMOCON	Remocon input
16	AM ILLUMI	No use	56	J BUS INT	J-BUS interrupt
17	CD ILLUMI	No use	57	BAND	FM/AM band selection
18	DIMMER OUT	No use	58	MONO	FM mono selection
19	LM0	CD loading motor output	59	IFRQ/AGC	During FM auto search, IF request output H after SD detected. During AM auto search, AGC output.
20	LM1	CD loading motor output			
21		No use	60	MUTE	Muting switch
22		No use	61	LEVEL	Level meter input
23		No use	62	S METER	S meter input
24	KS2	No use	63	KEY CHANGE	Connect to ground
25	KS1	No use	64	KEY2	Key 2 data input (AD)
26	KS0	Output for initial setting diode matrix	65	KEY1	Key 1 data input (AD)
27	DETACH	Front panel detect	66	KEY0	Key 0 data input (AD)
28	K2	No use	67	PSAVE1	Power save 1, ACC power detect
29	K1	Input for initial setting diode matrix	68	SENSE	Voltage sense
30	K0	Input for initial setting diode matrix	69		No use
31	Vdd	5V power supply	70	FM IF COUNT	FM IF counter data input
32	SW2	CD mechanism switch 2 for 12cm disc	71		No use
33	CD LSI RESET	CD LSI reset	72		No use
34	MCLK	CD LSI command clock signal	73	Vdd	5V power supply
35	MDATA	CD LSI command data output	76	AM OSC	No use
36	MLD	CD LSI command load signal	75	FM OSC	FM input frequency
37		No use	76	Vss	Ground
38		No use	77		No use
39	SCL	E.volume clock output	78	EO	PLL error output signal
40	SDA	E.volume data output	79	TEST1	Connect to ground
			80	XOUT	4.5MHz crystal oscillation

HA13164(IC901):Regulator

1.Terminal layout



2.Block diagram

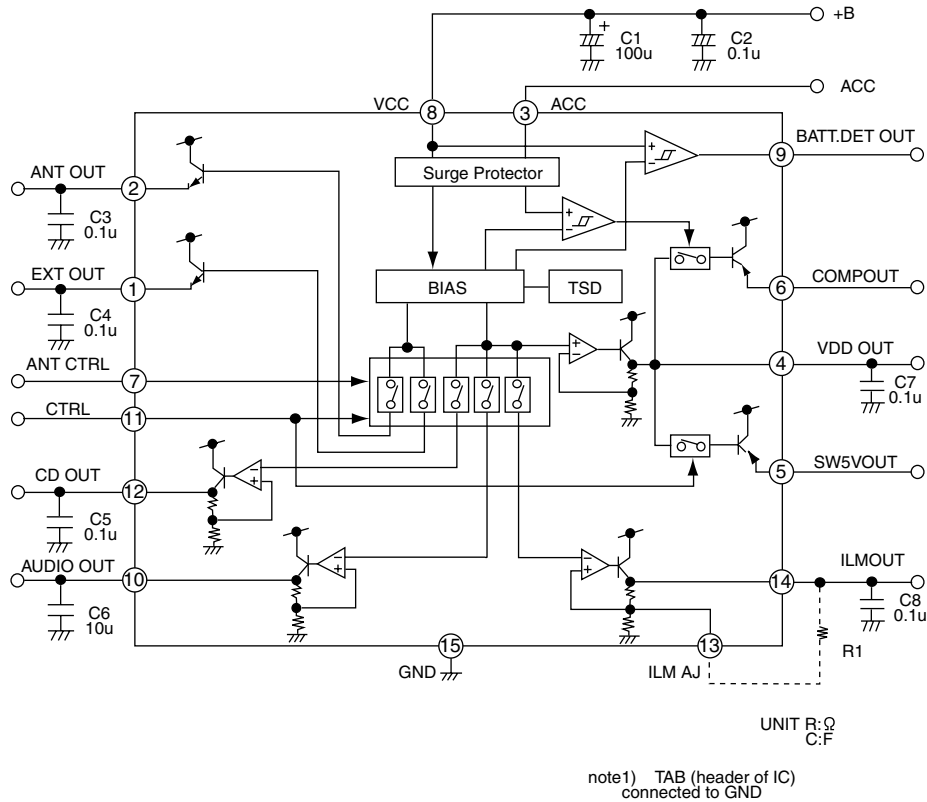

3.Pin function

Pin No.	Symbol	Function
1	EXTOUT	Output voltage is VCC-1 V when M or H level applied to CTRL pin.
2	ANTOUT	Output voltage is VCC-1 V when M or H level to CTRL pin and H level to ANT-CTRL.
3	ACCIN	Connected to ACC.
4	VDDOUT	Regular 5.7V.
5	SW5VOUT	Output voltage is 5V when M or H level applies to CTRL pin.
6	COMPOUT	Output for ACC detector.
7	ANT CTRL	L:ANT output OFF , H:ANT output ON
8	VCC	Connected to VCC.
9	BATT DET	Low battery detect.
10	AUDIO OUT	Output voltage is 9V when M or H level applied to CTRL pin.
11	CTRL	L:BIAS OFF, M:BIAS ON, H:CD ON
12	CD OUT	Output voltage is 8V when H level applied to CTRL pin.
13	ILM AJ	Adjustment pin for ILM output voltage.
14	ILM OUT	Output voltage is 10V when M or H level applies to CTRL pin.
15	GND	Connected to GND.

■ HD74HC126FP-X (IC631) : Buffer

1. Terminal layout

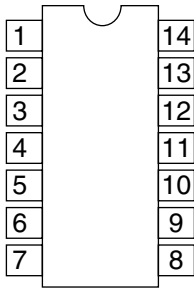

3. Pin function

Input		Outout
C	A	Y
L	X	Z
H	L	H
H	H	L

2. Block diagram

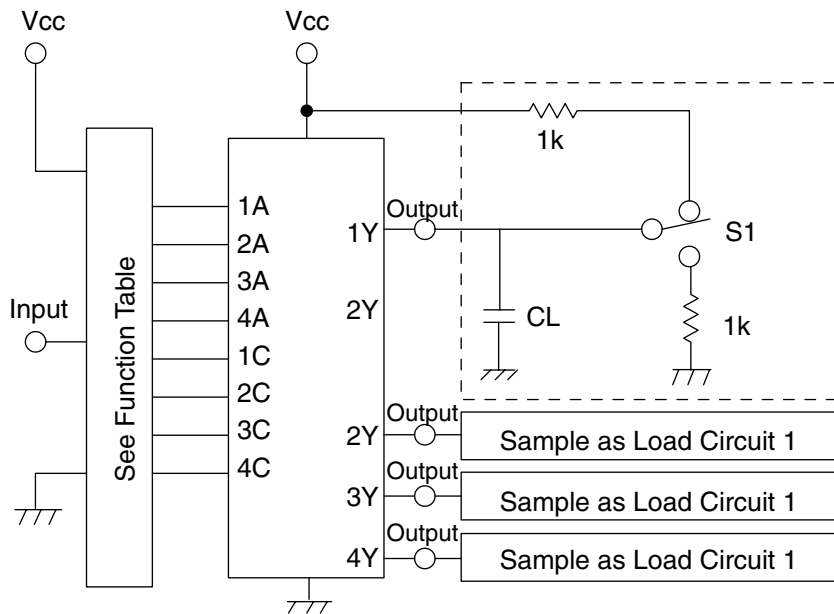

■ RPM6938-SV4 (IC602) : Remote sensor

1. Block diagram

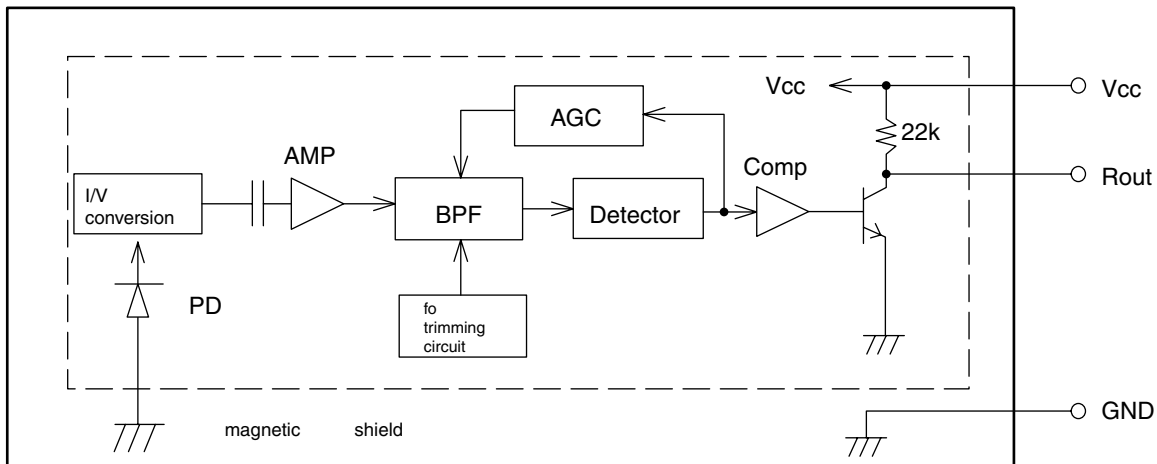

■ LC75823W (IC601) : LCD driver

1. Pin Layout & Symbol

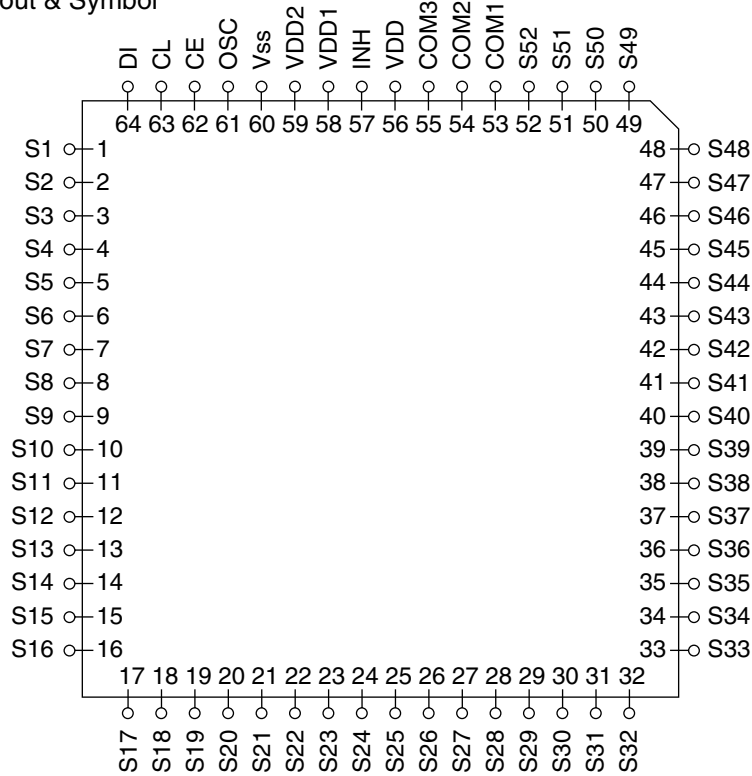

2. Pin Function

Pin No.	Symbol	I/O	Function
1 to 52	S1 to S52	O	Segment output pins used to display data transferred by serial data input.
53 to 55	COM1 to COM3	O	Common driver output pins. The frame frequency is given by : $t_0 = (f_{osc}/384)Hz$.
56	VDD	--	Power supply connection. Provide a voltage of between 4.5 and 6.0V.
57	\overline{INH}	I	Display turning off input pin. $\overline{INT} = "L"$ (Vss) ----- off (S1 to S52, COM1 to COM3="L") $\overline{INT} = "H"$ (VDD)----- on Serial data can be transferred in display off mode.
58	VDDD1	I	Used for applying the LCD drive 2/3 bias voltage externally. Must be connected to VDD2 when a 1/2 bias drive scheme is used.
59	VDD2	I	Used for applying the LCD drive 1/3 bias voltage externally. Must be connected to VDD1 when a 1/2 bias drive scheme is used.
60	Vss	--	Power supply connection. Connect to GND.
61	OSC	I/O	Oscillator connection. An oscillator circuit is formed by connecting an external resistor and capacitor at this pin.
62	CE	I	Serial data interface connection CE : Chip enable
63	CL	I	to the controller. CL : Sync clock
64	DI	I	DI : Transfer data

JVC

VICTOR COMPANY OF JAPAN, LIMITED

MOBILE ELECTRONICS DIVISION

PERSONAL & MOBILE NETWORK BUSINESS UNIT. 10-1,1Chome,Ohwatari-machi,Maebashi-city,Japan